

Egg, Alexandra, Orly, Fortuny

***pallucco***

Egg pag 2, Alexandra pag 12, Orly pag 22,  
Fortuny Bronze Rubelli & Pétite pag 32.

Egg  
design, Enrico Franzolini

Un progetto che recupera un'antica tecnica artigianale, la soffiatura del vetro in gabbia, per creare un oggetto luminoso, ambrato e organico, come un bozzolo appoggiato o sospeso nell'ambiente.

A design which brings back an ancient craft technique, that of the glass blowing in a cage, to create a luminous, ambered and organic object like a cocoon standing or suspended in the room.

La soffiatura dona al vetro lievi irregolarità nella forma e minuscole bolle d'aria che sembrano fluttuare nella materia, rendendo unica ogni singola realizzazione. La struttura metallica a vista, con il suo gioco grafico, dona a questa lampada una forte personalità anche quando è spenta.

The blowing gives the glass slight irregularities in the shape and tiny bubbles of air which appear to float in the material, making each single creation unique. The exposed metal structure, with its graphic play, gives this lamp a strong personality even when switched off.



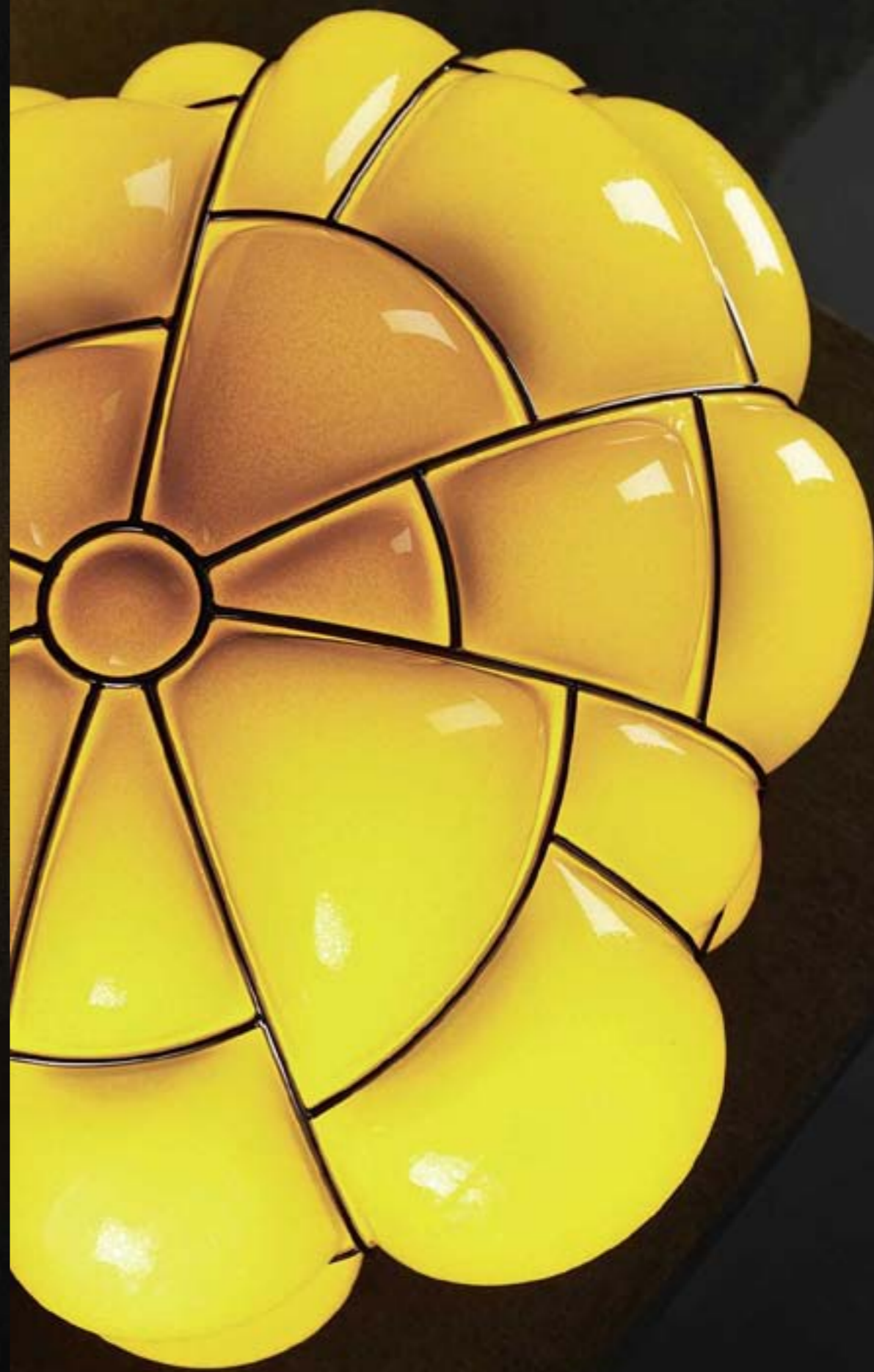







# Egg

sospensione, tavolo  
/ pendant, table

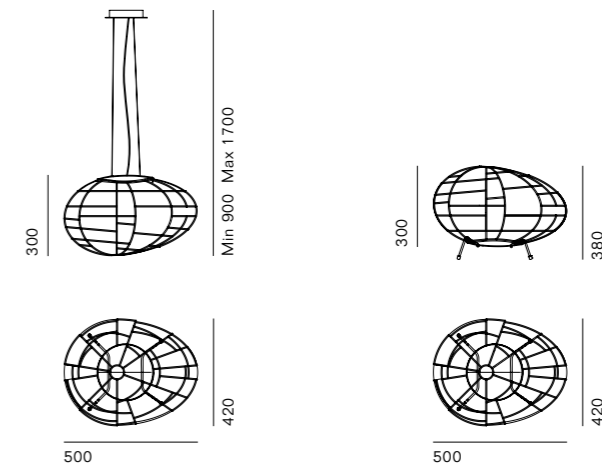

Una lampadina dimmerabile Master Led MV 18Watt, luce calda 2700°K, attacco E27, durata 25.000hr, 1521 Lumen.

Per la versione 110V si consiglia lampadina dimmerabile A-Shape Led 20Watt, attacco E26, durata 25.000hr, 1621 Lumen.

One dimmable Master Led MV 18Watt light bulb, warm light 2700°K, E27 socket, duration 25.000hr, 1521 Lumen.

For 110V version, a dimmable A-Shape Led 20Watt, E26 socket, duration 25.000hr, 1621 Lumen.

Eine dimmbare Glühbirne Master Led MV 18Watt, warmes Licht 2700°K, Sockel E27, Lampenlebensdauer 25.000 Stunden, 1521 Lumen.

Für die Version 110V ist eine regulierbare Glühbirne A-Shape Led 20Watt, Sockel E26, Lampenlebensdauer 25.000 Stunden, empfiehlt.

Une ampoule dimmable Master Led MV 18Watt, lumière chaude 2700°K, douille E27, durée de l'ampoule 25.000 heures, 1521 Lumen.

Pour la version 110V on souhaite une ampoule dimmable A-Shape Led 20Watt, douille E26, durée de l'ampoule 25.000 heures, 1621 Lumen.

Una bombilla regulable Master Led MV 18Watt, lux caliente 2700°K, conexión E27, duración de la bombilla 25.000 horas, 1521 Lumen.

Por la versión 110V le recomendamos una bombilla regulable A-Shape Led 20Watt, conexión E26, duración de la bombilla 25.000 horas, 1621 Lumen.

Alexandra  
design, Enrico Franzolini

Le lampade in vetro della tradizione veneziana,  
le rigorose geometrie di Piet Mondrian e le aeree  
composizioni di Alexander Calder: tre ispirazioni che  
confluiscono in un nuovo concetto di lampada.

Traditional Venetian glass lamps,  
the rigorous geometries of Piet Mondrian  
and the airy compositions of Alexander Calder:  
three inspirations which converge in a  
new lighting concept.

Sovrapponendo diversi fogli sottili di fibra di vetro, con nervature in trasparenza che disegnano motivi organici, prende forma un oggetto inedito e materico, capace di diffondere nell'ambiente, insieme alla luce, una sensazione di leggerezza e di presenza al tempo stesso. La scelta fra diversi colori aggiunge personalità e possibilità al progetto.

By overlapping various thin sheets of glass fibre, with ribs showing through and tracing organic patterns, an exclusive, textural object takes shape, able to diffuse in the room, together with the light, a sensation of weightlessness and presence at the same time. The choice between different colours adds personality and potential to the design.











# Alexandra

## sospensione / pendant

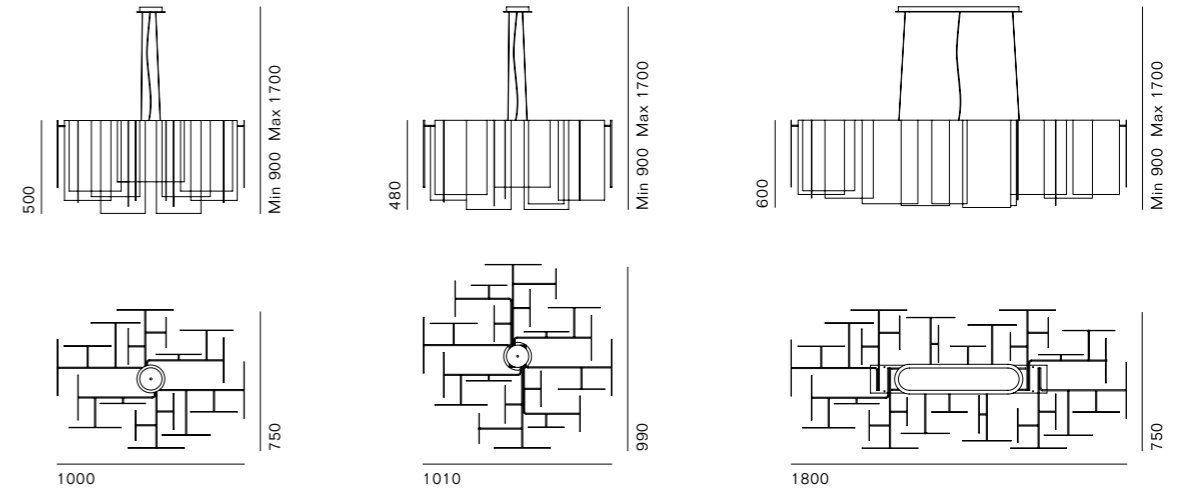

Una lampadina  
globo Ø120 mm  
compatta fluorescente  
elettronica 30Watt,  
luce calda 2700°K,  
attacco E27.

Per la versione 110V  
stessa lampadina  
23Watt,  
attacco E26.

One globo compact  
electronic fluorescent  
30Watt light bulb,  
Ø120 mm,  
warm light 2700°K,  
E27 socket.

For 110V same  
light bulb,  
23Watt,  
E26 socket.

Eine kompakte  
elektronische  
Leuchtstofflampe  
Globo Ø120 mm  
30Watt,  
warmes Licht 2700°K,  
Sockel E27.

Für die Version 110V  
selbe Glühbirne,  
23Watt,  
Sockel E26.

Une ampoule  
fluorescente compacte  
électronique globo  
Ø120 mm 30Watt,  
lumière chaude  
2700°K,  
douille E27.

Pour la version 110V  
même ampoule,  
23Watt,  
douille E26.

Una bombilla  
fluorescente compacta  
electrónica globo  
Ø120 mm 30Watt,  
lux caliente 2700°K,  
conexión E27.

Por la versión 110V  
misma bombilla,  
23Watt,  
conexión E26.

Orly  
design, Enrico Franzolini

Una famiglia di lampade che esplora nuove sensazioni luminose, sperimentando l'utilizzo di una maglia metallica in due diverse finiture acciaio e bronzo.

A family of lamps which explores new light sensations, experimenting the use of a metal mesh in two different finishes of steel and bronze.

I paralumi dalla forma estremamente lineare, così rivestiti risultano avvolgenti e assumono un valore architettonico oltre che d'arredo. La sorgente luminosa si intravede dall'esterno, ma senza abbagliare lo sguardo, mentre la luce si diffonde nell'ambiente e accende riflessi preziosi sulla trama metallica.

The shades with their strongly linear shape, covered in this way, appear to envelop the lamp and take on an architectural as well as an interior design value. The light bulb can be seen from the outside yet without dazzling, while the light is diffused in the room and lights up precious glints on the braided metal.











Orly  
terra, sospensione, tavolo  
/ floor, pendant, table

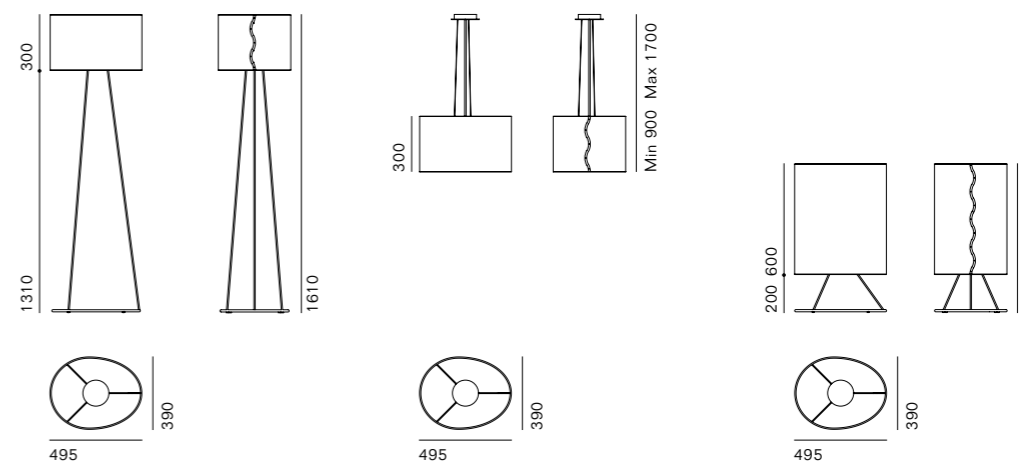

Una lampadina dimmerabile Master Led MV 18Watt, luce calda 2700°K, attacco E27, durata 25.000hr, 1521Lumen.

Per la versione 110V si consiglia lampadina dimmerabile A-Shape Led 20Watt, attacco E26, durata 25.000hr, 1621Lumen.

One dimmable Master Led MV 18Watt light bulb, warm light 2700°K, E27 socket, duration 25.000hr, 1521Lumen.

For 110V version, a dimmable A-Shape Led 20Watt, E26 socket, duration 25.000hr, 1621Lumen.

Eine dimmbare Glühbirne Master Led MV 18Watt, warmes Licht 2700°K, Sockel E27, Lampenlebensdauer 25.000 Stunden, 1521Lumen.

Für die Version 110V ist eine regulierbare Glühbirne A-Shape Led 20Watt, Sockel E26, Lampenlebensdauer 25.000 Stunden, empfiehlt.

Une ampoule dimmable Master Led MV 18Watt, lumière chaude 2700°K, douille E27, durée de l'ampoule 25.000 heures, 1521Lumen.

Pour la version 110V on souhaite une ampoule dimmable A-Shape Led 20Watt, douille E26, durée de l'ampoule 25.000 heures, 1621 Lumen.

Una bombilla regulable Master Led MV 18Watt, lux caliente 2700°K, conexión E27, duración de la bombilla 25.000 horas, 1521Lumen.

Por la versión 110V le recomendamos una bombilla regulable A-Shape Led 20Watt, conexión E26, duración de la bombilla 25.000 horas, 1621Lumen.

## Fortuny Bronze Rubelli & Pétite design, Mariano Fortuny y Madrazo

Nella storia del design sono pochi i progetti capaci di prestarsi a interpretazioni sempre nuove, mantenendo un'inconfondibile personalità.

There are very few designs in design history that are suited to always new interpretations while retaining a distinctive personality.

È il caso della lampada Fortuny, creata nel 1907 dall'artista, scenografo e imprenditore tessile veneziano Mariano Fortuny, sovvertendo i canoni estetici e illuminotecnici dell'epoca. Riproposta negli anni da Pallucco sia nella versione originale, nata per creare un'illuminazione diffusa, sia in molteplici riedizioni che esplorano l'universo dei tessuti e del fashion design, Fortuny si presenta in una veste ulteriore, creata con stoffe artigianali della famosa tessitura Rubelli. Un "black dress" esterno in tessuto James Dean, con texture semilucida simile alla raffia, abbinato a un interno in lino laminato con fili di bronzo, che mantiene l'effetto di luce riflessa, ma al tempo stesso sorprende con la sua tonalità scura.

One example is the Fortuny lamp created in 1907 by the Venetian textiles trader, stage designer and artist Mariano Fortuny, overturning the technical lighting and aesthetic rules of the time. Reintroduced over the years by Pallucco both in the original version, intended to create diffused lighting, and in many new versions which explore the world of fabrics and fashion design, Fortuny appears in another outfit created with artisan fabrics from the famous textiles company Rubelli. An outer "black dress" in James Dean fabric with a semi-shiny texture similar to raffia, matched with a lining in laminated linen with bronze threads, which maintains the reflected light effect yet at the same time is surprising in its dark colour.







## Fortuny Bronze Rubelli & Pétite terra / floor

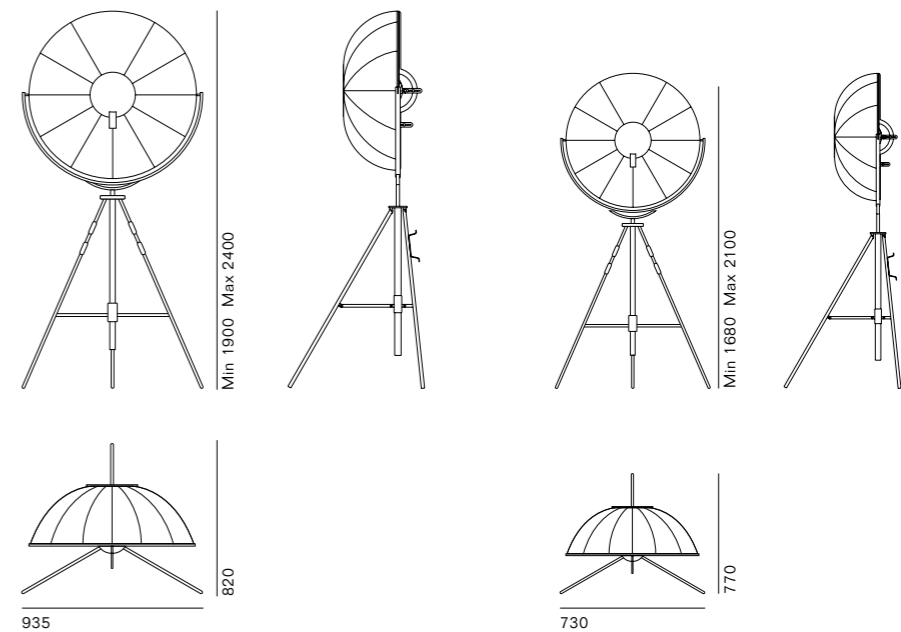

Una lampadina ad incandescenza da 500Watt, 8400Lumen o da 300Watt, 4600Lumen (Pétite), durata 1000hr, dimmer sul cavo.

Versione Led, un Led di potenza 48Watt, 3000°K 5000Lumen oppure 32Watt, 3000°K, 3500Lumen (Pétite), durata 50.000hr, dimmer sul cavo.

One incandescent 500Watt, 8400Lumen or 300Watt, 4600Lumen (Pétite), light bulb, socket E40 duration 1000hr.

For the Led version one power Led 48Watt, 3000°K, 5000Lumen or 32Watt, 3000°K, 3500Lumen (Pétite), duration 50.000hr, both equipped with dimmer.

Eine Glühbirne 500Watt, Sockel E40 Lichtfluss 8400Lumen, oder Glühbirne 300Watt Lichtfluss 4600Lumen (Pétite), Die Glühbirnen dauern 1000 Stunde.

Für Led Version, ein power Led 48Watt warmes Licht, 3000°K, 5000Lumen oder 32Watt, 3000°K, 3500Lumen (Pétite), Der power Led dauert 50.000 Stunden, Beide Versionen sind mit Dimmer ausgestattet.

Une ampoule incandescente 500Watt douille E40, flux lumineux 8400Lumen, ou 300Watt douille E40 flux lumineux 4600Lumen (Pétite), durée de l'ampoule 1000 heures.

Pour la version Led, un power Led 48Watt lumière chaude 3000°K, 5000Lumen, ou 32Watt, 3000°K, 3500Lumen (Pétite), durée du power Led 50.000 heures, le dimmer est monté sur les deux versions.

Una bombilla incandescente 500Watt, conexión E40 8400Lumen, o 300Watt, conexión E40, 4600Lumen (Pétite), duración de la bombilla 1000 horas.

Por la version Led, 1 power Led 48Watt, Luz caliente 3000°K, 5000Lumen, o un power Led 32Watt, Luz caliente 3000°K, 3500Lumen (Pétite), duración 50.000 horas, dimmer ya montado en ambas versiones.

Art direction  
Enrico Franzolini

Concept & Graphics  
Barazzuol / Malisan

Photography  
Alessandro Bon

Copywriter  
Daniele Varelli

Colour separation  
Luce Group

Print  
Grafiche Filacorda  
April, 2015

FORTUNY Design: Mariano Fortuny y Madrazo terra / floor	4	CORAL Design: Studio Lagranja terra, sospensione, terra-tavolo / floor, pendant, floor-table	14
FORTUNY PÉTITE Design: Mariano Fortuny y Madrazo terra / floor	6	CRINOLINA Design: Susanne Philippon terra, sospensione, tavolo / floor, pendant, table	15
PAPIRO Design: Sergio Calatroni terra / floor	7	BOLLE Design: Joe Colombo terra / floor	16
GILDA & BABY GILDA Design: Enrico Franzolini terra, sospensione / floor, pendant	8	ROCK GARDEN Design: Kazuhiro Yamanaka sospensione / pendant	17
FARO Design: Hannes Wettstein terra, tavolo, sospensione / floor, table, pendant	10	BREEZE Design: Kazuhiro Yamanaka contenitori / storage units	18
GLOW Design: Enrico Franzolini & Vicente Garcia Jiménez terra, sospensione / floor, pendant	11	NEXT BASIC Design: Studio Hannes Wettstein contenitori / storage units	19
JOIIN Design: Susanne Philippon terra, sospensione / floor, pendant	12	ASNAGO VENDER Design: Mario Asnago & Claudio Vender tavolo / tables	20
FOLD Design: Enrico Franzolini terra, sospensione, applique / floor, pendant, wall	13	CONTINUA Design: Hannes Wettstein libreria / bookshelf	21
		COLOR INDEX	22

LA RICERCA CONTINUA FRA  
ARTE E INDUSTRIA

Dall'inizio degli anni 80 al presente, Pallucco si conferma come un sinonimo di cultura del progetto, ispirazione artistica e sperimentazione coraggiosa. Un filo ininterrotto lega i suoi esordi, nel segno della contaminazione con il mondo della moda, attraverso la collaborazione con il fotografo Peter Lindbergh e la stilista Rei Kawakubo; la riedizione della lampada Fortuny, capolavoro visionario e preveggenete dei primi del Novecento, divenuta un'icona inconfondibile dell'azienda italiana; il minimalismo degli anni Novanta, con la direzione artistica di Hannes Wettstein; l'esplorazione di sempre nuove frontiere e linguaggi nel mondo del design, negli anni Duemila, con la guida di Jurgen Bey. Un'evoluzione originale e anticonformista, che ha dato vita a una collezione multiforme, senza mai rinunciare a un'identità forte e unica, espressione di valori culturali e tecnologici profondi. Con nuove energie societarie, nuovo Art Director Enrico Franzolini, nuovi progetti e nuove collaborazioni nel mondo del design, Pallucco inaugura il capitolo presente e futuro, di una storia che continua a coinvolgere, sorprendere e affascinare: oltre il tempo, nella contemporaneità.

ONGOING EXPLORATION IN BOTH  
ART AND INDUSTRY

From the early 80s to the present day Pallucco has become established as a byword for design culture, artistic inspiration and bold innovation. By way of fusion in its early years it enjoyed uninterrupted links with the fashion world through work with the photographer Peter Lindbergh and the fashion designer Rei Kawakubo. The new version of the Fortuny lamp, a visionary and forward-looking masterpiece from the early twentieth century, became an unmistakable icon of the Italian company; the minimalism of the Nineties, under the artistic direction of Hannes Wettstein; the exploring of ever-new frontiers and idioms in the design world in the new millennium under the guidance of Jurgen Bey. An original and unconventional development which has given life to a polyhedral collection without ever foregoing a strong and unique identity, the expression of profound technological and cultural values. With new corporate energies, a new Art Director, Enrico Franzolini, new design projects and new design partnerships, Pallucco is embarking on the present and future chapter in a story which continues to involve, surprise and attract, beyond time, in the contemporary age.

"Comme des Garçons N.3, N.4, N.5"  
Design: Rei Kawakubo  
Year: 1986



"Lizie"  
Design: Régis Protière  
Year: 1984



"Comme des Garçons N.1, N.2"  
Design: Rei Kawakubo  
Year: 1986



"Mattatoio 1988",  
Salone del Mobile  
Milano





Fortuny  
Design: Mariano  
Fortuny y Madrazo  
Year: 1907

4

terra / floor



Fortuny Led



Fortuny Moda



Fortuny Rubelli

5

Fortuny Pétite  
Design: Mariano  
Fortuny y Madrazo  
Year: 2012

6

terra / floor

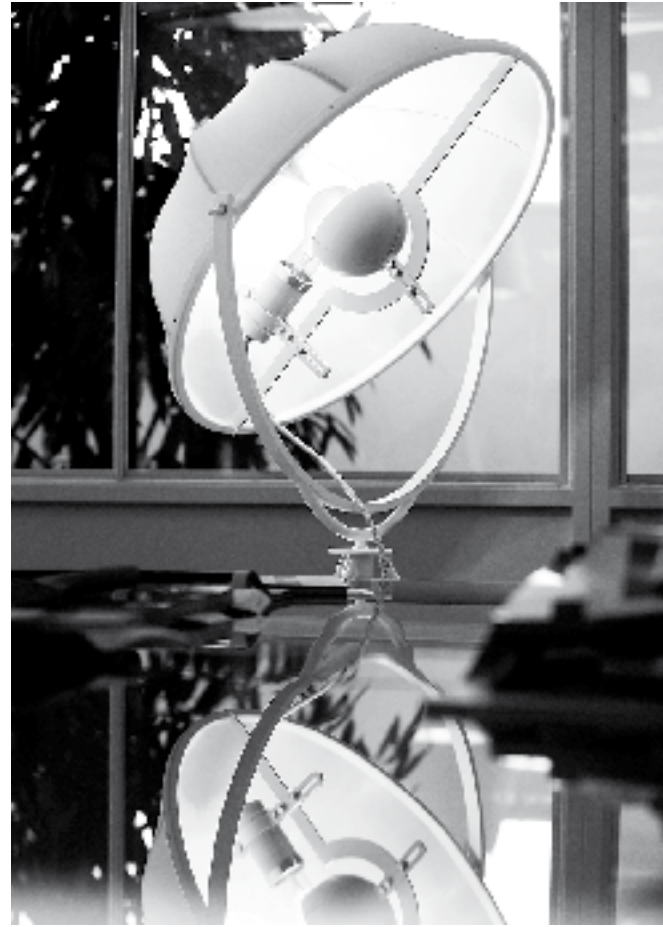

Fortuny Rubelli

Papiro  
Design: Sergio Calatroni  
Year: 1989

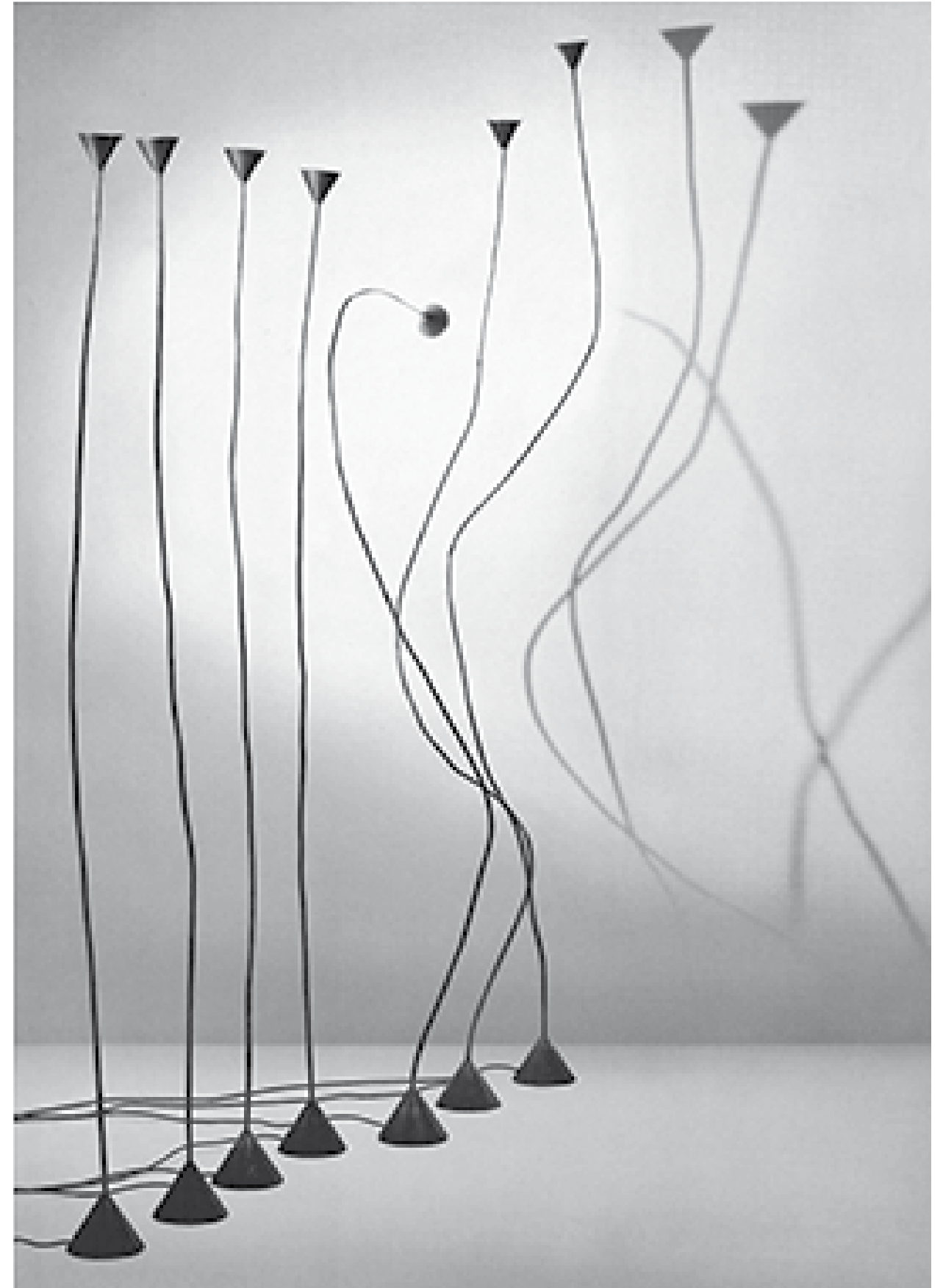

Papiro terra / floor

7



Gilda terra / floor



Gilda sospensione / pendant



Gilda Led & Baby Gilda Led



Baby Gilda

Faro  
Design: Hannes Wettstein  
Year: 2000

10

tavolo, sospensione  
/ table, pendant



Faro terra / floor

Glow  
Design: Enrico Franzolini &  
Vicente Garcia Jiménez  
Year: 2005

terra / floor



Glow Square sospensione / pendant

Joiin  
Design: Susanne Philippson  
Year: 2007

12



Joiin sospensione / pendant



Joiin terra / floor

Fold  
Design: Enrico Franzolini  
Year: 2008

terra, applique  
/ floor, wall



Fold sospensione / pendant





Coral terra / floor



Coral sospensione / pendant



Crinolina terra / floor



Crinolina tavolo / table



Crinolina sospensione / pendant



Bolle terra / floor

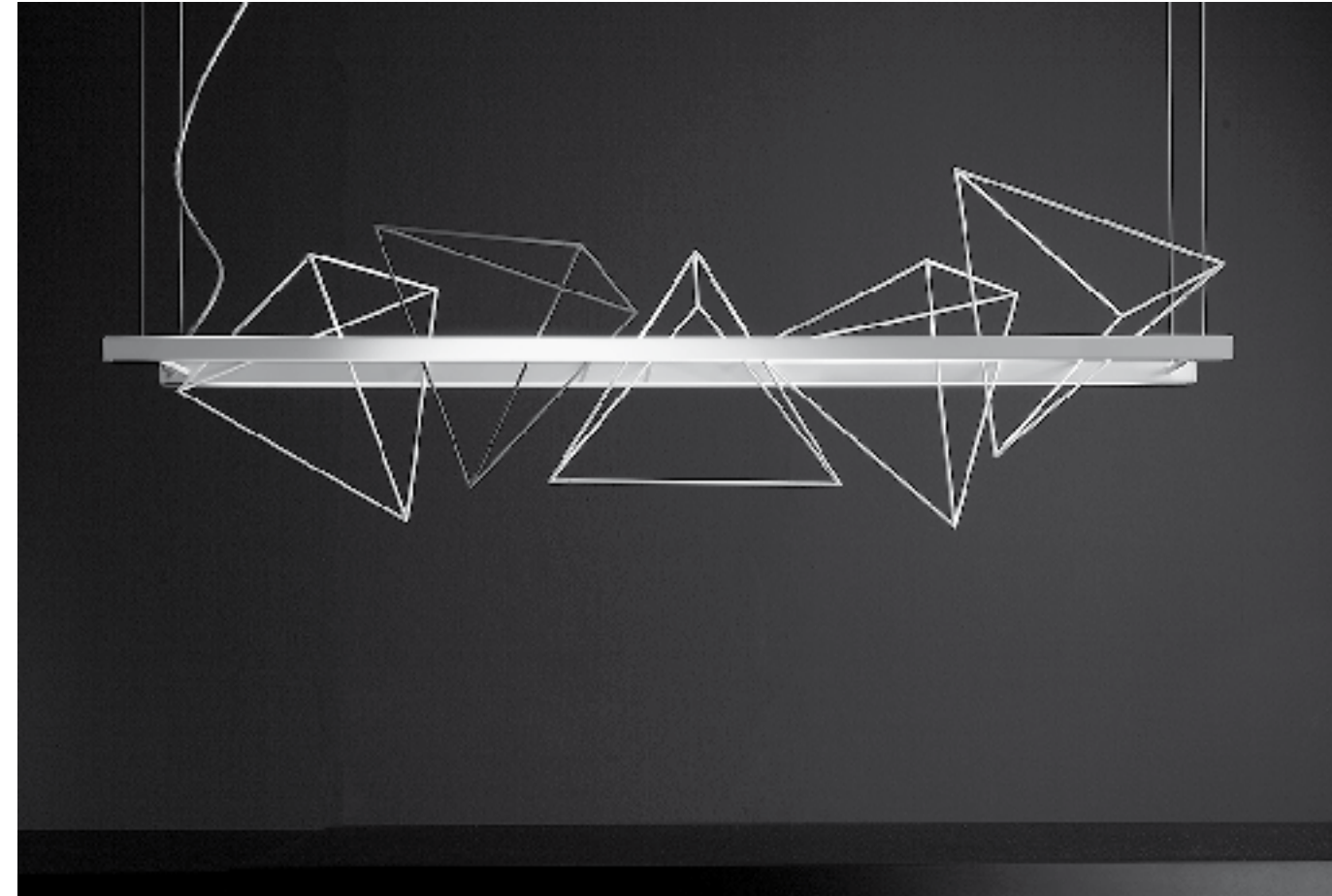

Rock Garden Big sospensione / pendant

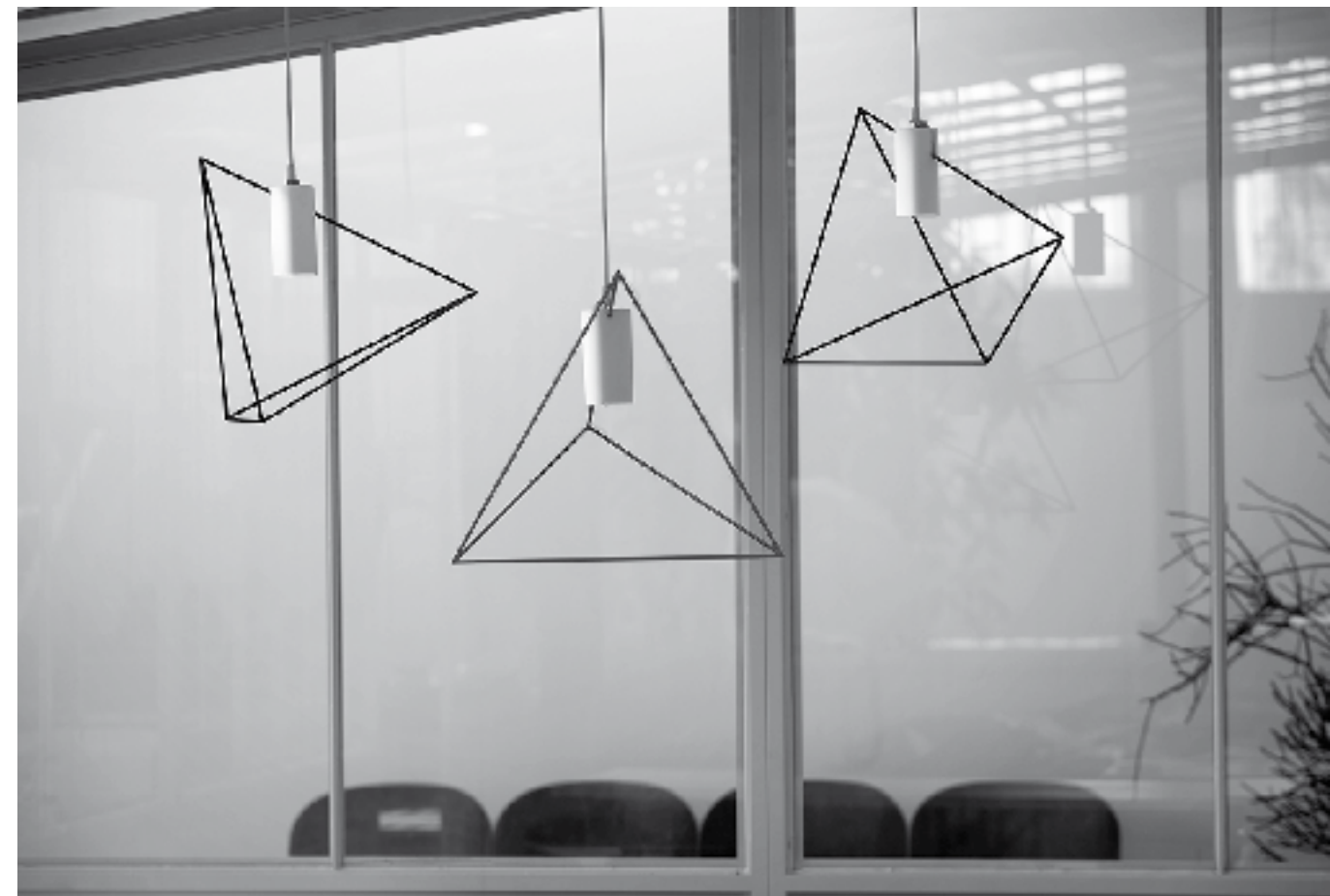

Rock Garden Spot sospensione / pendant

Design: Kazuhiro Yamanaka  
Year: 2006



Grande Breeze

Design: Studio Hannes Wettstein  
Year: 2012





Asnago Vender  
Design: Mario Asnago &  
Claudio Vender  
Year: 1936

20

tavolo / tables



Continua  
Design: Hannes Wettstein  
Year: 1992

libreria / bookshelf





FORTUNY

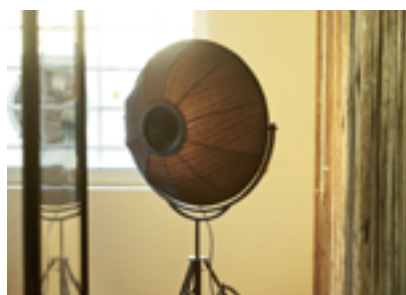

FORTUNY PÈTITE



PAPIRO

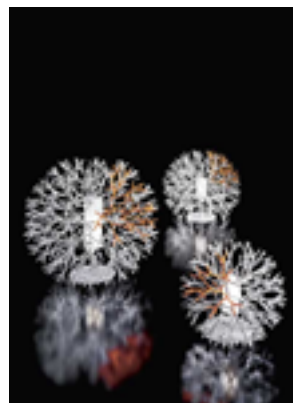

CORAL



CRINOLINA



BOLLE



GILDA



BABY GILDA

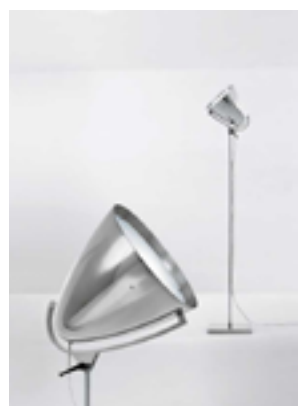

FARO



ROCK GARDEN



BREEZE



NEXT BASIC



GLOW



JOIN



FOLD



ASNAGO VENDER



CONTINUA



Pallucco, Kubo Srl

Sede legale

Registered office

Kubo Srl

N 4670 – San Marco

30124, Venezia

Italy

Sede operativa

Headquarters

Kubo Srl

N 36 – via Azzi

Castagnole di Paese

31038 Treviso, Italy

Commerciale Italia

T +39 0422 43 86 00

Export Department

T +39 0422 43 86 22

info@pallucco.com

www.pallucco.com